

## User Manual

### CRM 3000 and CRM 3000 Variable Threshold (VT)



---

DUAL INVENTIVE | BELGIËSTRAAT 5 | 5061 KG OISTERWIJK

Telephone: +31 (0)13 5339969

Date: February 2025

Email: [info@dualinventive.com](mailto:info@dualinventive.com)

Version: 1.2.0

Website: <https://dualinventive.com/en/>

User manual: Original

---

# TABLE OF CONTENTS

<b>1</b>	<b>Version History .....</b>	<b>5</b>
<b>2</b>	<b>Preface .....</b>	<b>6</b>
2.1	Purpose user manual .....	6
2.2	Users of CRM 3000 .....	6
2.3	Reading guide .....	7
2.4	Abbreviations.....	7
<b>3</b>	<b>Introduction.....</b>	<b>8</b>
3.1	Intended use.....	8
3.2	Non-intended use.....	8
3.3	Specifications.....	8
3.3.1	CRM 3000 Specifications .....	8
3.3.2	MTinfo 3000-Insight Web Specifications.....	10
3.3.3	MTinfo 3000-Insight Mobile Specifications.....	10
3.4	Worksite .....	10
<b>4</b>	<b>Product description .....</b>	<b>11</b>
4.1	CRM 3000.....	11
4.2	Identification .....	13
4.3	MTinfo 3000-Insight web and mobile app 'The RailCloud – Work Management' .....	13
4.4	Terms of use .....	13
4.4.1	CRM 3000 .....	13
4.4.2	MTinfo 3000-Insight web and the app.....	13
<b>5</b>	<b>Safety .....</b>	<b>15</b>
5.1	General.....	15
5.1.1	Intended use .....	15
5.1.2	Non-intended use .....	15
5.2	General safety instructions.....	15
5.3	Residual risks .....	15
5.4	Personal Protective Equipment.....	15
5.5	Safety symbols.....	16
<b>6</b>	<b>Installation and Removal .....</b>	<b>17</b>
6.1	Before Installation .....	17
6.2	Installation .....	17

6.3	Removal.....	18
<b>7</b>	<b>Changing locations.....</b>	<b>19</b>
7.1	Changing locations manually.....	19
7.2	Synchronizing with a smart device's location.....	19
<b>8</b>	<b>Troubleshooting.....</b>	<b>20</b>
<b>9</b>	<b>Service.....</b>	<b>21</b>
9.1	Service of CRM 3000 standard and VT.....	21
9.2	Lifespan.....	21
9.3	Warranty and delivery conditions.....	21
<b>10</b>	<b>Contact.....</b>	<b>22</b>

## List of Tables

Table 1: Reading guide .....	7
Table 2: Abbreviations.....	7
Table 3: CRM 3000 Specifications .....	9
Table 4: Specifications MTinfo 3000-Insight.....	10
Table 5: MTinfo 3000-Insight Mobile Specifications.....	10
Table 6: Residual risks .....	15
Table 7: Safety symbols.....	16
Table 8: Warning and error messages .....	20
Table 9: Update Frequency for CRM 3000 VT.....	21

# 1 VERSION HISTORY

VERSION NUMBER	DATE	CHANGE LOG	REFERENCE
1.2.0	11.02.2025	Modification: Temperature range	<u>Service of CRM 3000 standard and VT, All</u>
1.1.0	02.05.2024	Modifications:	
		<ul style="list-style-type: none"> <li>• Rebranded</li> <li>• Insight to MTinfo 3000-Insight</li> </ul>	All
		Additions:	
		<ul style="list-style-type: none"> <li>• Explanation of CRM 3000 Variable Threshold</li> </ul>	<u>2.1, 9</u>
		<ul style="list-style-type: none"> <li>• Version History</li> </ul>	
		Deletion:	
		<ul style="list-style-type: none"> <li>• Insight web and mobile application</li> </ul>	

## 2 PREFACE

Please read this manual carefully. The correct understanding and execution of the instructions is obligatory for using the CRM 3000 safely and correctly. Keep this manual handy whenever you are working with CRM 3000.

This manual is also available at <https://dualinventive.com/en/downloads/>. If you encounter any ambiguities while using the CRM 3000, report them via [info@dualinventive.com](mailto:info@dualinventive.com) or by telephone.

The CRM 3000 is designed to contribute to the *optimal distribution of rail capacity*, considering the ease and safety of track monitoring.

No rights can be derived from the information in this user manual. The reproduction or distribution in print, written and/or audio-visual form is prohibited, unless Dual Inventive has permitted this beforehand.

Dual Inventive has originally written this manual in English. If anything is unclear or deviates from the original in a translated version, the original English document is leading.

### 2.1 Purpose user manual

The purpose of this user manual is to instruct the user on the correct and safe use of the CRM 3000. The CRM 3000 is a *sensor for the remote monitoring of railway systems*, combined with the web and mobile application versions of MTinfo 3000-Insight.

There are *two versions of the CRM 3000*: the *standard version*, which updates its data every hour and the *Variable Threshold (VT) version*, which uploads data based on the temperature it measures. The thresholds of the VT versions are pre-configured by Dual Inventive in collaboration with customers

This user manual contains instructions regarding:

1. Personal safety and product safety that must be observed to avoid risks that could lead to physical and/or property damage.
2. Use of the CRM 3000.

### 2.2 Users of CRM 3000

Typical users of the CRM 3000 are:

1. *The work planner* prepares and manages the web interface MTinfo 3000-Insight and assigns the location for installing the CRM 3000s on the railway track.
2. *The installer* is the track worker responsible for installing the CRM 3000 on the railway track.
3. *The end user* monitors the track temperature.

Every user of the CRM 3000 must be authorized by the administrator of the user's company for the right access and user rights for MTinfo 3000-Insight.



#### NOTE

The CRM 3000 must only be used by trained, certified, and competent users.

## 2.3 Reading guide

To alert the reader to *safety issues and important information*, the following symbols and terms are used in this manual:





SYMBOL	MEANING
	<b>DANGER</b> Indicates a hazardous situation which could result in death or serious injury (of the individual) if the safety instructions are not followed.
	<b>WARNING</b> Indicates a hazardous situation which could result in death or serious injury and/or damage to the product or the surrounding area if the safety instructions are not followed.
	<b>CAUTION</b> Indicates a hazardous situation which could result in minor and/or moderate damage to the product or the surrounding area if the safety instructions are not followed.
	<b>NOTE</b> Provides important information.
	<b>NOTE</b> Refers to a document.

Table 1: Reading guide

## 2.4 Abbreviations

ABBREVIATION	MEANING
CRM 3000	Critical Rail Monitor 3000
NB-IoT	Narrow Band Internet of Things
PPE	Personal Protective Equipment
VT	Variable Threshold

Table 2: Abbreviations

## 3 INTRODUCTION

### 3.1 Intended use

The CRM 3000 is intended to *remotely monitor railway systems*. The CRM 3000 measures the *rail temperature* and its *orientation on the track*. The CRM 3000 is used in combination with the *MTinfo 3000-Insight web application* and the *MTinfo 3000-Insight mobile app* 'The RailCloud - Work Management'. Both applications are used for monitoring and management of one or more CRM 3000.

### 3.2 Non-intended use

Any other use than the intended use is prohibited.



#### WARNING

Non-intended use could have consequences for the personal safety and can cause material damage to the CRM 3000 and its surroundings.



#### NOTE

In case of non-intended use, the warranty of the CRM 3000 is voided.

### 3.3 Specifications

#### 3.3.1 CRM 3000 Specifications

S/N	SPECIFICATION	VALUE
1.	Compatible rail profiles	All rail profiles
2.	Weather conditions	All weather conditions
3.	Telecommunication	NB-IoT
4.	Temperature measurements	Between -25 °C and +70 °C (Accuracy of $\pm 0.50^{\circ}\text{C}$ )
5.	Orientation	3-axis (X, Y, Z) accelerometer
6.	Update frequency	Update sent to MTinfo 3000-Insight every hour (this is varying for the CRM 3000 VT version)
7.	IP protection level	IP 65
8.	Weight	310 g



S/N	SPECIFICATION	VALUE
9.	Dimensions	Diameter: 80 mm Height: 45 mm
10.	Battery life	~5 years (depending on update frequency; this is varying for the CRM 3000 VT version)

*Table 3: CRM 3000 Specifications*



**NOTE**

The update frequency for CRM 3000 can be changed to either one hour or 15 minutes for an additional fee.

### 3.3.2 MTinfo 3000-Insight Web Specifications

S/N	SPECIFICATION	VALUE
1.	Internet	Broadband
2.	Web browser	Google Chrome latest version (recommended) Microsoft Edge latest version
3.	Recommended software	Adobe Acrobat as PDF reader to view reports

Table 4: Specifications MTinfo 3000-Insight

### 3.3.3 MTinfo 3000-Insight Mobile Specifications

S/N	SPECIFICATION	VALUE
1.	Internet	5G or Wi-Fi
2.	Device	Processor at least 1.5 GHz Internal memory at least 2,048 MB Screen resolution of at least 1,366p by 768p

Table 5: MTinfo 3000-Insight Mobile Specifications



**NOTE**

If the specifications for the required software and hardware are incorrect or missing, Dual Inventive bears no responsibility for any resulting consequences.

## 3.4 Worksite

Always ensure your safety when entering the railway environment. Follow the applicable *local regulations* and *organizational procedures*.

## 4 PRODUCT DESCRIPTION

### 4.1 CRM 3000

The CRM 3000 is a *sensor for remote monitoring of railways*. For the user, the CRM 3000 is a 'black box', as it cannot be opened and lacks control buttons. The compact device is *magnetically attached* to the object being monitored, ensuring simple and swift installation.

The standard CRM 3000 has an *internal battery* built to last for a default period of 5 years.



**NOTE**

The lifetime of CRM 3000 varies based on usage and area connectivity.



Figure 1 CRM 3000 (all views)

POS	LEGEND	POS.	LEGEND
1.	Top view	3.	Front view with identification
2.	Bottom view		

The CRM 3000 measures the *temperature* of the object and its *orientation through X, Y and Z axis values*. The temperature measurement is intended for reliable monitoring of changes in rail and object temperatures. The orientation measurement is intended to monitor the alignment of

objects, such as signs, relay cabinets or signals. The orientation measurements can also be used to indicate whether the CRM 3000 has fallen off or has been removed from the object.

The CRM 3000 communicates with MTinfo 3000-Insight using *NB-IoT* technology. The measured values are reported back to the user via MTinfo 3000-Insight. In this way, users can both monitor and manage all CRM 3000 devices easily using the MTinfo 3000-Insight applications.

## 4.2 Identification

The CRM 3000 has an ID sticker with a serial number and a QR-code (see Figure 1).

## 4.3 MTinfo 3000-Insight web and mobile app 'The RailCloud – Work Management'

The CRM 3000 device works with the MTinfo 3000-Insight web and the mobile application 'The RailCloud-Work Management'.



### NOTE

For more details on the MTinfo 3000-insight web application 'The RailCloud-Work Management', please check their respective manuals on the *Dual inventive website*.

## 4.4 Terms of use

### 4.4.1 CRM 3000

1. *Non-SIL certification:* The CRM 3000 is not SIL (Safety Integrity Level) rated and is therefore not certified to be used for safety purposes.
2. *Quarantine and Damage control:* Do not use the CRM 3000 if it has been damaged or shows defects. Quarantine the CRM 3000. The CRM 3000 should not have major damage; a slight scratch is acceptable. Please contact Dual Inventive.
3. *Professional repair:* Never perform repairs to the CRM 3000 yourself.
4. *Installation safety measures:* Make sure that when installing the CRM 3000, the device does not get damaged by on-track equipment or other tools in line with local regulations.
5. *Precautions:* Avoid dropping the CRM 3000. The device contains components that can withstand shocks and vibrations, but the device can break down.

### 4.4.2 MTinfo 3000-Insight web and the app



### WARNING

Always respond promptly to service alerts from MTinfo 3000-Insight (set by the customer) when issues arise.

1. *Authorized usage:* You must only use MTinfo 3000-Insight when you are authorised by the user company for the correct right access and user rights. Dual Inventive creates a user account for the company. This user account is the company's administrator and is the nominated contact person for your company. The administrator is responsible for creating and managing users and their respective rights for using Dual Inventive product(s), in such a manner that misuse is avoided. You are responsible for keeping your password secret and working safely with Dual Inventive products.
2. *Missing login information:* If you have lost login details, immediately contact the company administrator within your organization to block the account to avoid misuse. If internet is available, please go to MTinfo 3000-Insight and change the password to avoid misuse.

3. *Compatibility issues:* Incompatible hardware, software settings, firewalls etc. could limit the connection to MTinfo 3000-Insight. When you encounter any issues, please discuss it with your IT staff.
4. *Browser and device support:* See Table 4 and visit <https://www.dualinventive.com> to find out which browsers and devices are supported by MTinfo 3000-Insight and the app. If needed, request support from Dual Inventive.
5. *NB-IoT connection requirement:* To use the functionality of the CRM 3000, a stable NB-IoT connection is needed. In areas with a poor NB-IoT connection, the CRM 3000 may lose its connection to MTinfo 3000-Insight. This means that no data is transmitted to MTinfo 3000-Insight.
6. *App compatibility:* To use the functionality of the app, use a compatible mobile phone.
7. *Internet connectivity:* Make sure the internet is always connected when working with the MTinfo 3000-Insight web or mobile app.

## 5 SAFETY

### 5.1 General

#### 5.1.1 Intended use

For safe use, only use the CRM 3000 for its intended use.

#### 5.1.2 Non-intended use

Non-intended use of the CRM 3000 can cause malfunctioning and unsafe situations like electrocution, fire or other dangerous situations.

### 5.2 General safety instructions

Specific safety instructions are part of the installation, preparation and configuration of the CRM 3000, which are described in these sections. In addition, follow these general safety instructions:

1. Installation of the CRM 3000 must be performed only when a *worksite is protected from trains*, by the relevant rail infrastructure controller's safe track access instructions.
2. Guarantee safety while installing the CRM 3000. The user is responsible for a safe installation. Follow the *local, national and organizational regulations and procedures*.



#### WARNING

The user is responsible for the safe installation of the CRM 3000.

### 5.3 Residual risks

Dual Inventive has performed a risk assessment of the CRM 3000 for the intended use and normal operating conditions. The following acceptable, residual risks are present with the intended use and the normal operating conditions:

HAZARD	RESIDUAL RISK
Magnetic field	The CRM 3000 has a strong magnet to ensure a firm attachment to the rail or object. The magnetic field can damage electrical equipment. The magnetic field can disturb a pacemaker.

Table 6: Residual risks

### 5.4 Personal Protective Equipment

Due to the standard safety measures and PPE for track workers, there is no need for extra PPE while using the CRM 3000.

## 5.5 Safety symbols

In accordance with the residual risks, the CRM 3000 has the following safety symbols to warn the user:

SYMBOL	Description	WARNING
	Dangerous for people with active implanted cardiac devices.	Users with a pacemaker are not allowed to use the CRM 3000.

*Table 7: Safety symbols*



## 6 INSTALLATION AND REMOVAL

This section describes how to install the CRM 3000 in the track and to remove it from the track.

### 6.1 Before Installation



**WARNING**

Before installing or removing the CRM 3000, check the worksite and make sure that everything is safe.

Before installing the CRM 3000, ensure that the CRM 3000 is functioning properly by checking its temperature in the MTinfo 3000-Insight web or the mobile app.

The last time the temperature has been updated, must be less than *2 hours ago* and the measured temperature must be within the expected temperature range of its environment.

If the CRM 3000 is not working properly, wait one more hour because the data might be slightly delayed. If this does not help, [contact Dual Inventive](#).

### 6.2 Installation



**WARNING**

Be aware of the risk of trapping your fingers and never place them on the magnetic side of the device.

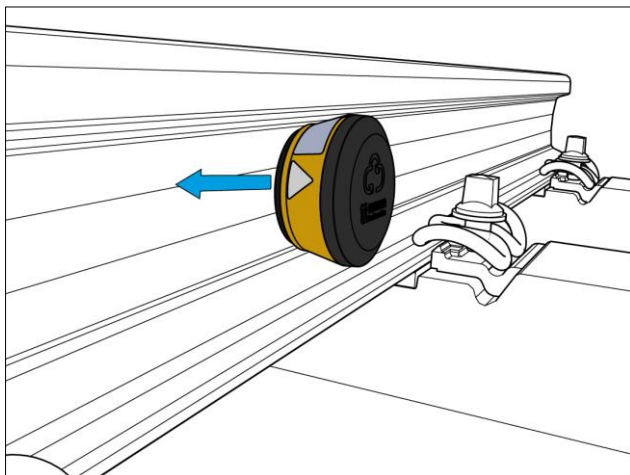

1. Place the CRM 3000 on the shaded side of the rail to ensure that the rail temperature is measured correctly.
2. Place the CRM 3000 vertically so that the *ID sticker* is visible after placing it.

## 6.3 Removal

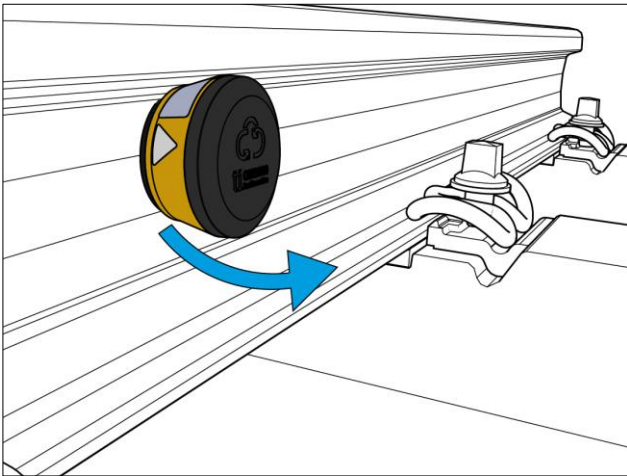

1. Place the thumb on the top of the device and grasp the bottom firmly with your fingers.
2. Pull up the device. If needed, use the foot of the rail as a grip point for your fingers.



### **WARNING**

Do not twist and turn the CRM 3000 while it is installed on the track or attached to another metal surface. This can permanently damage the device.

## 7 CHANGING LOCATIONS

The CRM 3000 cannot automatically update its location. If needed, the asset's location can be changed manually through MTinfo 3000-Insight web and/or the app. There are two ways to do this:

1. Change the location by selecting a new location manually;
2. Change the location by synchronising it with your smart device's location.

### 7.1 Changing locations manually

The location of a CRM 3000 can be changed manually through MTinfo 3000-Insight web or the app:

1. MTinfo 3000-Insight web: go to the 'Assets' section and locate the device on the map. The CRM 3000 will be displayed on the map.

MTinfo 3000-Insight mobile app: go to the 'Assets' section and locate the device on the map. The CRM 3000 will be displayed on the map.



2. Click this button.

3. Select where you wish to place the CRM 3000. Zoom in and out with the scroll wheel of your mouse or use the + and – buttons on your smart device.

4. Click the check button to confirm the device's new location OR click the cancel button to cancel the new location.

### 7.2 Synchronizing with a smart device's location

The location of a CRM 3000 can be changed by synchronizing it with a smart device's location through the app:

1. App: navigate to Map to see the device's location.



2. Click this button to update the location.



3. You can press this button to synchronise the location with the location of your device.

4. Click the check button to confirm the device's new location OR click the cancel button to cancel the new location.

## 8 TROUBLESHOOTING



**NOTE**

If you frequently receive warning and/or error messages, please contact Dual Inventive.

Refer to Table 8 below to follow up on warning and error messages. If the solution does not work, please contact Dual Inventive.

DESCRIPTION	SOLUTION
CRM 3000 is offline.	<ul style="list-style-type: none"> <li>• Ensure the area you are in has good NB-IoT coverage. If you are unsure about this, contact Dual Inventive for assistance.</li> <li>• Wait for 24 hours. The CRM 3000 automatically resets itself after 24 hours of offline time.</li> </ul>
No notifications from CRM 3000 are received.	<ul style="list-style-type: none"> <li>• Ensure a threshold has been set on the CRM 3000 and that value has been exceeded.</li> <li>• Check if a notification channel has been assigned to this threshold and if the specific user has subscribed to this channel.</li> <li>• Check your settings to ensure you are subscribed to the notification channel and the expected notifications are enabled.</li> </ul>
CRM 3000 does not show certain points of data in the graphs.	The CRM 3000 does not update its status to MTinfo 3000-Insight retroactively if it is offline for an extended period. If there are data gaps in MTinfo 3000-Insight, this may be related to the network quality of the area in which the device is located.

*Table 8: Warning and error messages*

## 9 SERVICE

### 9.1 Service of CRM 3000 standard and VT

The CRM 3000 standard and VT service will be provided by Dual Inventive for up to 5 years for free. In case of problems, please contact your Dual Inventive support team for assistance.

The CRM 3000 Variable Threshold (VT) device works practically the same as the standard version, except the standard version updates every hour and the CRM 3000 VT version updates based on the temperature it is measuring and its settings.

For CRM 3000 VT, if the temperature measurement hits a new threshold and it needs to start updating more frequently, it will immediately adjust this and send an update. For instance, if the device hits the 15-20°C range, it will upload the temperatures, and then send hourly updates until the temperature reaches a different range.

If the device drops to the below 15 degrees temperature range, it will send the next update at the following moment when it meets its new criteria, in this case within 2 hours, from the moment it detected this drop.

The CRM 3000 VT allows users to respond to emergency temperature increases or decreases without having to compromise significant battery life.

The CRM 3000 VT temperature ranges will be predetermined.

The CRM 3000 VT has a maximum of 5 temperature limits - these can be configured by the customer as well as the cut-off for immediate notification.

An example of such a CRM 3000 VT could be as follows:

TEMPERATURE RANGE	UPDATE FREQUENCY
Below 15 degrees	Update every 2 hours
Between 15 – 20 degrees	Update every hour
Above 20 degrees	Update every 15 minutes
Above 30 degrees	Update every 5 minutes

*Table 9: Update Frequency for CRM 3000 VT*

### 9.2 Lifespan

The lifespan of the CRM 3000 standard version is roughly 5 years.

The lifespan of the CRM 3000 VT would vary depending on the update frequency.

### 9.3 Warranty and delivery conditions

The CRM 3000 is supported by a lease contract that contains Dual Inventive's warranty and delivery conditions.

## 10 CONTACT

The Netherlands:

---

BELGIËSTRAAT 5 | 5061 KG OISTERWIJK | THE NETHERLANDS

Telephone: +31 (0)13 5339969

Email: [info@dualinventive.com](mailto:info@dualinventive.com)

Website: <https://dualinventive.com/>

---

United Kingdom:

---

UNIT 3, KESTREL COURT | FIRST AVENUE | DONCASTER, DN9 3RN |

UNITED KINGDOM

Telephone: +44 (0)3300 169033

Email: [info@dualinventive.com](mailto:info@dualinventive.com)

Website: <https://dualinventive.com/en/>

**Support team UK**

Telephone: +44 (0)7903699807

Email: [support@dualinventive.co.uk](mailto:support@dualinventive.co.uk)

---